



HARD SEAT MINIATURE NEEDLE VALVES

CST Needle Valves have established a proven track record for quality, reliability and price performance. Manufactured and tested to very exacting standards at the ISO certified manufacturing facility, these valves are today in use in various industries worldwide.

TECHNICAL DATA

SIZES:	1/8" & 1/4"
BODY:	Barstock. CS ASTM A108 Plated or ASTM A479 316SS Straight Pattern
END CONNECTIONS	Screwed / Compression ends
STEM:	Close tolerance surface finish, cold rolled threads, ASME SA-479 Type 316SS
NEEDLE TIP:	Hardened & Ground
GLAND BODY:	SSL provided, CS, ASTM A108 plated or ASME SA-479 Type 316SS
GLAND PACKING:	PTFE
SEAT	Delrin®
HANDLE:	Aluminum Anodized Thumb Wheel
WASHER:	ASME SA-479 Type 316SS
PRESSURE/TEMP RATING:	Room Temp / Pressure 6000 PSI 500°F / Pressure 4000 PSI
TEST PRESSURES:	Body: Hydrostatic at 6000 PSI Seat & Gland: 1000 PSI with Nitrogen
OPTIONS:	'T' Bar Handle
DESIGN STANDARD:	CRN APPROVAL

Contact Us: Canada Sensors Technology Inc.
10 – 328 Wale Road
Victoria, BC V9B 0J6
Canada
250-588-8085
sales@canadasensors.com
www.canadasensors.com
Manufacturer of Advanced Technology
Level and Pressure Transmitters

Drawing References: DWG_HSM_NV_001

MISSION STATEMENT

Canada Sensors Technology Inc. strives to build a mutually positive and beneficial relationship with our customers, ensuring their long-term success, through the understanding of their needs and the needs of their customers.

We will listen to our customers and constantly improve our technologies as our customers' needs change with time.

Canada Sensors Technology Inc. is committed to providing the highest level of product quality and customer service. Canada Sensors Technology Inc. is ISO 9001:2015 certified.

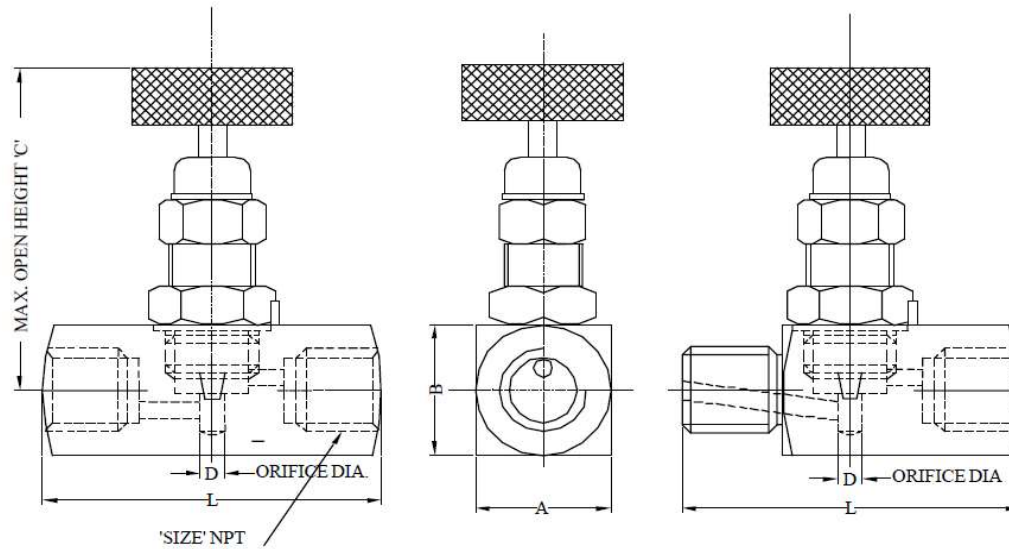

ALL DIMENSIONS ARE IN MM						
A	B	C	L	D	Cv	
22.0	22.0	62.0	48.0	3.2	0.25	

	CST PART NO.	SIZE	PATTERN	ENDS	MATL
Miniature Hard Seat Needle Valves	CST 0311	1/8"	G	FxF	SS316-ASTM A479
Miniature Hard Seat Needle Valves	CST 0312	1/4"	G	FxF	SS316-ASTM A479
Miniature Hard Seat Needle Valves	CST 0332	1/4"	G	MxF	SS316-ASTM A479
Miniature Hard Seat Needle Valves	CST 0511	1/8"	G	FxF	CS-ASTM A105
Miniature Hard Seat Needle Valves	CST 0512	1/4"	G	FxF	CS-ASTM A105
Miniature Hard Seat Needle Valves	CST 0532	1/4"	G	MxF	CS-ASTM A105

This drawing is the property of Canada Sensors Technology Inc.
Unauthorized reproduction is prohibited.

ALL DIMENSIONS ARE SUBJECT TO CHANGE WITHOUT ANY PRIOR NOTICE, TO BE USED FOR REFERENCE ONLY

DRAWN	CANADA SENSORS TECHNOLOGY INC.			
KH	06/04/2019	TITLE		
CHECKED	HARD SEAT MINIATURE NEEDLE VALVES			
QA				
MFG				
APPROVED	SIZE:	DWG NO.:	REV.	
		DWG_HSM_NV_001	0	
	SCALE:	SHEET 1 OF 1		